

Caddy® Tig 2200i AC/DC

For the craftsmen and a wide range of repair and maintenance applications

The Caddy® is already a classic power source in the mobile welding equipment field. With the introduction of the Caddy® Tig 2200i AC/DC series and a full range of accessories, you will find the optimal solution for a wide range of TIG welding applications.

Offering true portability

Not only is Caddy® Tig 2200i AC/DC small and of low weight. Thanks to its intelligent, compact design it is easy to take along to different indoor and outdoor worksites and also to tuck away when not used, making it handy both in the workshop and on the move.

Single phase mains connection makes it easy to find an electricity supply for the unit, and it works equally well when powered by a portable generator. *

Thanks to the built-in PFC circuit the machine can operate with extra long mains cables, over 100 m, giving the welder a very large working radius.

Impact resistant design

Composite materials in combination with smart design solutions provide a durable and impact resistant machine, adapted to rough conditions. The control panel is recessed, which provides additional protection and durability. Caddy® Tig 2200i AC/DC has sturdy and impact resistant cable connectors with OKC 50.

Improving the weld quality

With the TA33 version you only need to set the plate thickness. The machine controls the rest and can be trusted to always help the welder achieve consistent, high quality welding results. Hotter or colder welds can easily be obtained by adjusting the knob.

The TA34 version is designed to support and enhance the skills of the welder and enables excellent welding results to be achieved in a wide range of materials and thicknesses. The TA34 version comes with both adjustable slope up and slope down. It also comes with Micro Pulse functionality, making it easy to control the heat input and minimizing the heat affected zone. This is helpful especially on thin sheets and high tensile steels.

The Caddy® Tig 2200i AC/DC provides true MMA capability with the same capacity and features as ESAB MMA machines of the same voltage range, including the features Hot start, arc force setting, Arc Plus II* and additionally, polarity switch.

*To obtain full output, for use a 12 KVA portable generator with automatic voltage regulation

**Arc Plus II generates an intense yet smooth and stable arc that is easy to control. Smaller droplets are generated, the arc burns smoothly, and there is no need to pause at the edges when weaving. Arc Plus II offers even better welding characteristics, simplifies your work and gives you better weld quality with less need for post weld treatment.

Applications

- Repair and maintenance
- General light fabrication and civil construction
- Process industry
- Shipbuilding and offshore
- Transport and mobile machinery

XA00132320



Supporting the welder

The machine has true AC rating where the actual welding current is always equal to the set current.

The control panel is easy to overview and has a digital display for accurate welding parameter setting, high control and feedback. It is easy to understand and set, with or without gloves on. The TA34 version comes with two memories for pre-sets, enabling quick and accurate return to pre-defined settings.



Caddy® Tig 2200i AC/DC comes with a handy, ergonomic torch with a ball joint that decreases the stress on the welder's wrist and helps the welder access the material in confined spaces.

It can also easily be (retro)-fitted with a water cooler.

- Designed for quality TIG-welding in all types of material.
- Easy to use - all welding parameters presented in an easy to understand layout.
- QWave™ - enables AC welding with high arc stability and low noise.
- AC frequency and balance control (TA34 AC/DC) - optimises weld pool.
- Electrode preheating – excellent start and extended electrode life time (TA34 AC/DC)
- ESAB 2-program function - possibility to pre-program and change program during actual welding. (TA34 AC/DC)
- DC Pulsed TIG welding - easy control of heat input and the weld pool. (TA34 AC/DC)
- DC Micro Pulse – minimize heat affected zone especially on thin sheets (TA34 AC/DC)
- True MMA welding characteristics in AC and DC mode - Hot start, Arc force, and polarity switch (DC).

Technical data

	Tig 2200i AC/DC	
Mains supply, V/Ph Hz	230/1 50/60 Hz	
Fuse (slow), A	16	
Recommended generator size, KVA	12	
Mains cable, mm ²	3 x 2.5	
Maximum output		
at 20% duty cycle, TIG, A/V	220/18,8	
at 60% duty cycle, TIG, A/V	150/16,0	
Setting range TIG AC/DC, A	3-220	
Setting range MMA, A	4-160	
Open circuit voltage, V DC		
VRD inactive	46-60	
VRD active	<35	
Power factor		
at maximum current, at TIG mode	0,99	
Efficiency		
at maximum current, at TIG mode, %	66	
Dimensions LxWxH, mm	418x188x345	
Weight, kg	15	
Enclosure class	IP 23	
Application class		
Standards		
Operating temperature, °C	-10 to +40	
Water cooling unit CoolMini :		
Cooling capacity, W, l/min at 40°C	700/1,0	
Coolant volume, l	2,2	
Max flow, l/min	2	
Max pressure, 50/60 Hz, bar	2.3 bar	
Weight, kg	6,7	
External dimension, LxWxH, mm	418x188x137	
MMC panels :	TA34 AC/DC	TA33 AC/DC
Slope up, sec	0-10	-
Slope down, sec	0-10	0-10
Gas pre-flow*, sec	0-5	0-5
Gas post-flow, sec	0-25	0-25
Pulse -/ background time DC, sec	0,01-2,5	-
MicroPulse*time, sec	0,001-0,250	-
Frequency AC, Hz	10-152	65
AC balance, %	50-98	70
Plate thickness DC, mm	-	0,1-7,3
Plate thickness AC, mm	-	0,1-5,5

* hidden function

Ordering information

Caddy® Tig 2200i AC/DC, TA33 package incl. TIG torch TXH™ 201 4m	0460 150 882
Caddy® Tig 2200i AC/DC, TA34 package incl. TIG torch TXH™ 201 4m	0460 150 883
Caddy® Tig 2200i AC/DC, TA33 K4 package incl. Water cooler and TIG torch TXH™ 251w, 4m	0479 100 264
Caddy® Tig 2200i AC/DC, TA34 K4 package incl. Water cooler and TIG torch TXH™ 251w, 4m	0479 100 263
Caddy® Tig 2200i AC/DC, TA33 K4 package incl. Water cooler, TIG torch TXH™ 251w, 4m and trolley	0460 150 884
Caddy® Tig 2200i AC/DC, TA34	0460 150 881
Caddy® Tig 2200i AC/DC, TA33 package Cooling unit, CoolMini	0460 150 880 0460 144 880

Included in all packages: 3 m mains cable with plug, 2 m gas hose, 2 hose clamps and 3 m return cable with clamp.

Caddy® Tig 2200i AC/DC

For industrial use and for advanced repair and maintenance with water cooler



Accessories

Shoulder strap	0460 265 003
Trolley (for 5 to 10 l gas cylinder)	0459 366 885
Trolley (for 20 to 50 l gas cylinder)	0459 366 887
Trolley (for 20 to 50 l gas cylinder)	0459 366 880
Foot pedal T1 Foot CAN incl. 5 m cable	0460 315 880
Remote control AT1 CAN	0459 491 883
Remote control AT1 CoarseFine CAN	0459 491 884
Remote control MTA1 CAN	0459 491 880
Connections for cables for remote controls:	
5 m cable CAN	0459 554 880
10 m cable CAN	0459 554 881
TIG torch TXH™ 201 OKC50, 4m	0700 300 552
TIG torch TXH™ 251w OKC50, 4m	0700 300 561
TIG torch TXH™ 251wF OKC50, 4m	0700 300 562
TIG torch TXH™ 201F OKC50, 4m	0700 300 554
TIG torch TXH™ 251wr OKC50, 4m	0700 300 632
TIG torch TXH™ 251wFr OKC50, 4m	0700 300 633
TIG torch TXH™ 201r OKC50, 8m	0700 300 630
TIG torch TXH™ 200 Fr OKC50, 4m	0700 300 629
Warrior Tech Helmet Black	0700 000 400
Warrior Tech Helmet Yellow	0700 000 401
Welding gloves TIG Basic	0700 653 532
Esab Curved TIG gauntlet, L	0700 005 041

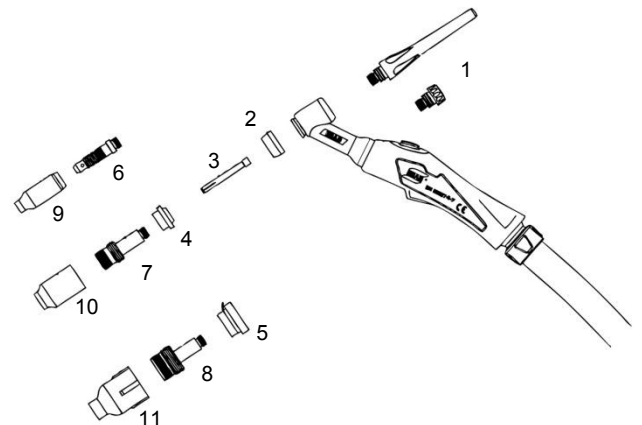

- | | |
|--------------------------------------|---|
| 1. Back cap | 6. Collet body, standard |
| 2. Heat shield | 7. Collet body with lens |
| 3. Collet, standard and for gas lens | 8. Collet body, extra large lens |
| 4. Heat shield | 9. Gas nozzle, standard |
| 5. Heat shield | 10. Gas nozzle, for gas lens |
| | 11. Extra large gas nozzle for extra large gas lens |

ESAB AB
Box 8004
SE-402 77 GÖTEBORG SWEDEN
Phone: +46 31 50 90 00 Fax +46 31 22 04 49
E-mail: info@esab.se

www.esab.com



**COMPANY WITH
MANAGEMENT SYSTEM
CERTIFIED BY DNV**
= ISO 9001 =
= ISO 14001 =
= OHSAS 18001 =